

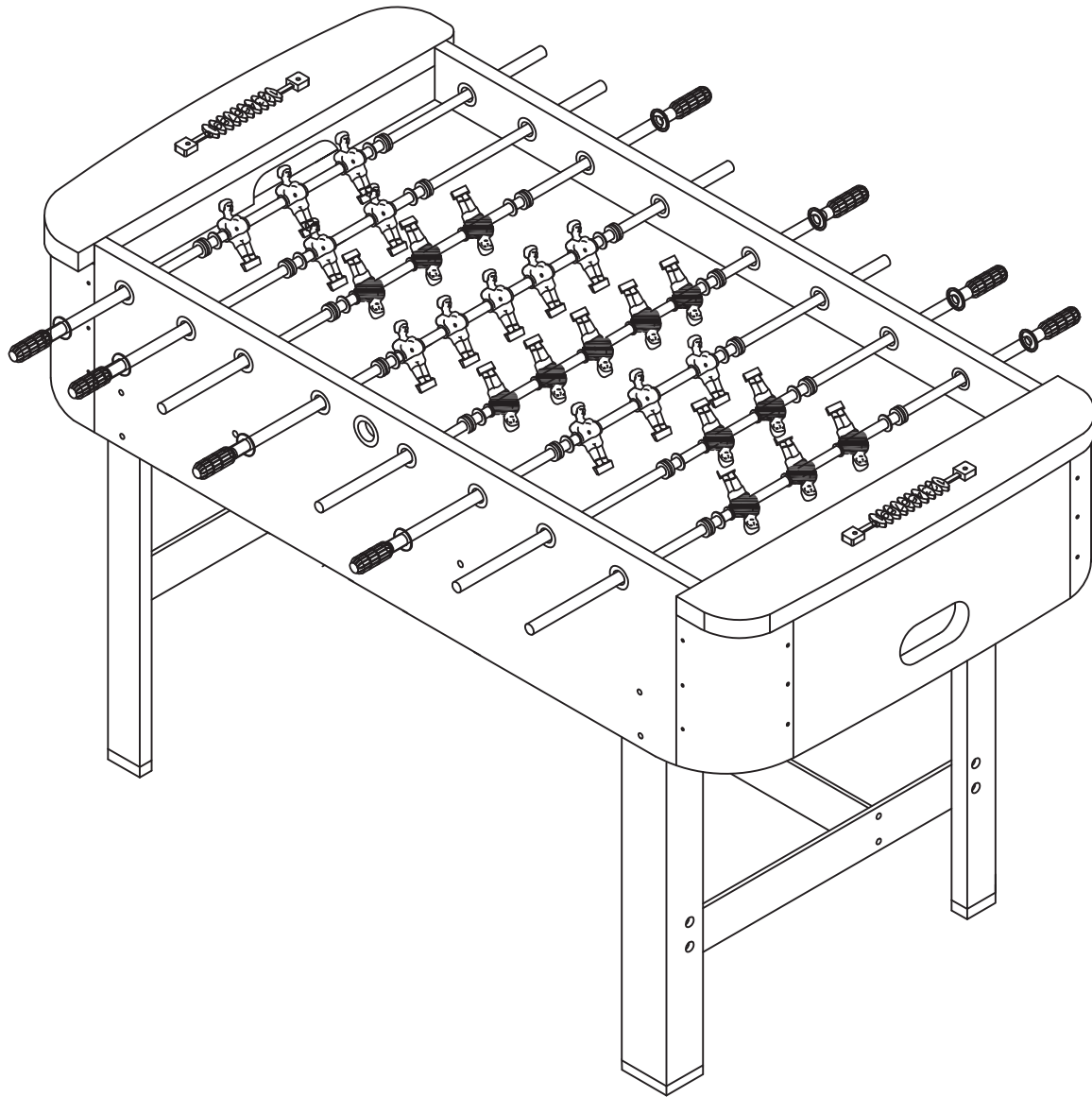

4' Soccer Table

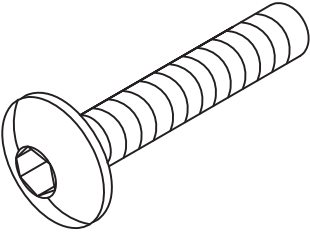
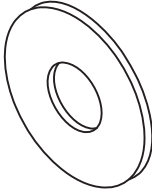
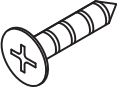
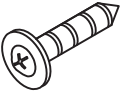
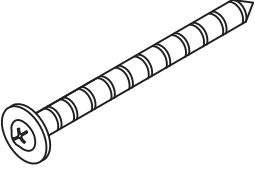
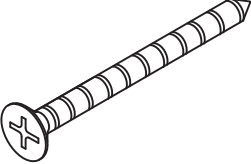
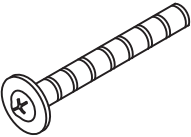
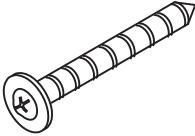

#900355

Parts List For 900355

 <p>H1 - M6 x 1-3/16" Bolt (12)</p>	 <p>H2 - M6.5 Flat Washer (12)</p>	 <p>H3 - T3.5 x 7/8" Screw (4)</p>
 <p>H4 - T3.5 x 3/4" Screw (16)</p>	 <p>H5 - T3.5 x 2-1/16" Washer Head Screw (4)</p>	 <p>H6 - T3.5 x 2-1/16" Flat Head Screw (8)</p>
 <p>H7 - T4 x 1" Bolt (8)</p>	 <p>H8 - T3.5 x 1-3/16" Washer Head Screw (4)</p>	 <p>T1 - Wrench (1)</p>
 <p>A1 - Soccer Ball (2)</p>		

Parts List For 900355

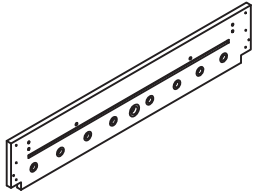

P1 - Side Apron
(2)

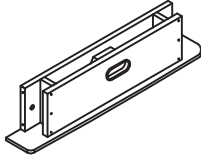

P2 - End Apron
(2)

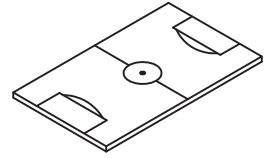

P3 - Playfield
(1)

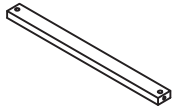

P4 - Support Brace
(2)

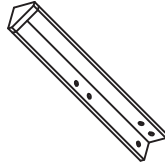

P5 - Left Leg
(2)

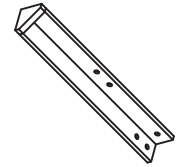

P6 - Right Leg
(2)

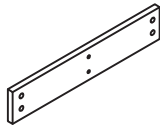

P7 - End Leg Panel
(2)

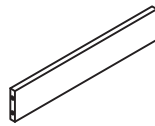

P8 - Middle Leg Panel
(1)

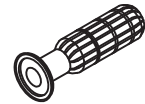

P9 - Rod Handle
(8)



P10 - Rod End Cap
(8)

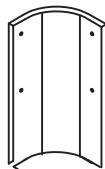

P11 - Apron Corner
(4)

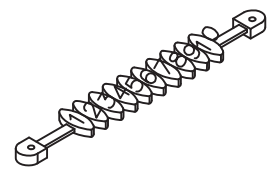

P12 - Red Scorer
(1)

Parts List For 900355

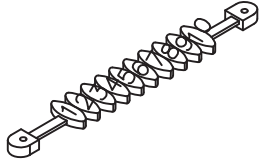

P13 - Blue Scorer
(1)

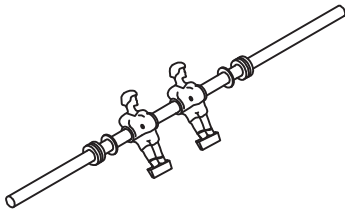

R1 - 2 Player Rod Blue (1)

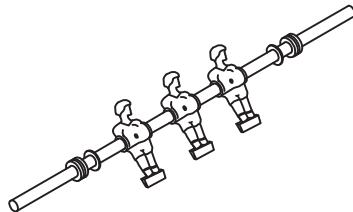

R2 - 3 Player Rod Blue (2)

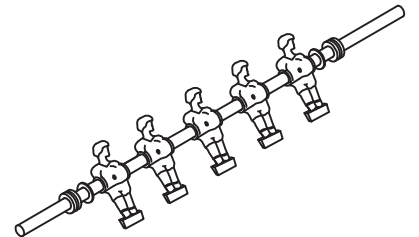

R3 - 5 Player Rod Blue (1)

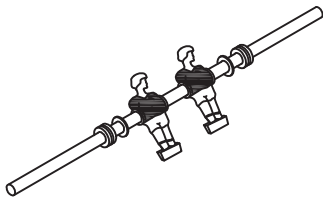

R4 - 2 Player Rod Red (1)

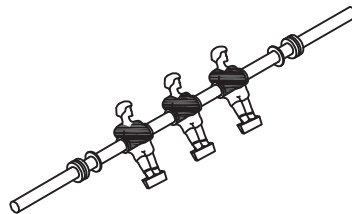

R5 - 3 Player Rod Red (2)

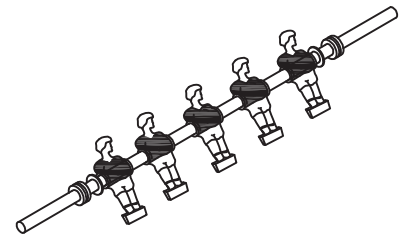

R6 - 5 Player Rod Red (1)



WARNING: Choking Hazard --Table contains small balls and/or small parts. Not for children under 6 years.

1. Find a clean, level place to begin the assembly of your soccer table. We recommend building the table on the box top to protect the parts during assembly.
2. Place one side apron **P1** *UPSIDE DOWN* with the finished side facing out as shown in **FIGURE 1**. The ball entry hole will be closest to the floor.
3. Align the rods as shown in **FIGURE 1**. Please note the location of the hole that is near one end of each rod. This is the handle end of the rod. There will be four handles on each side of the table. It is critical that you set the rods as shown below so the table will be correct when flipped over.
4. Once you are sure you have the rods set up correctly, slide the other side apron **P1** onto the rods as shown.



CAUTION:

Please set the rods as shown noting the location of the hole/handle end.

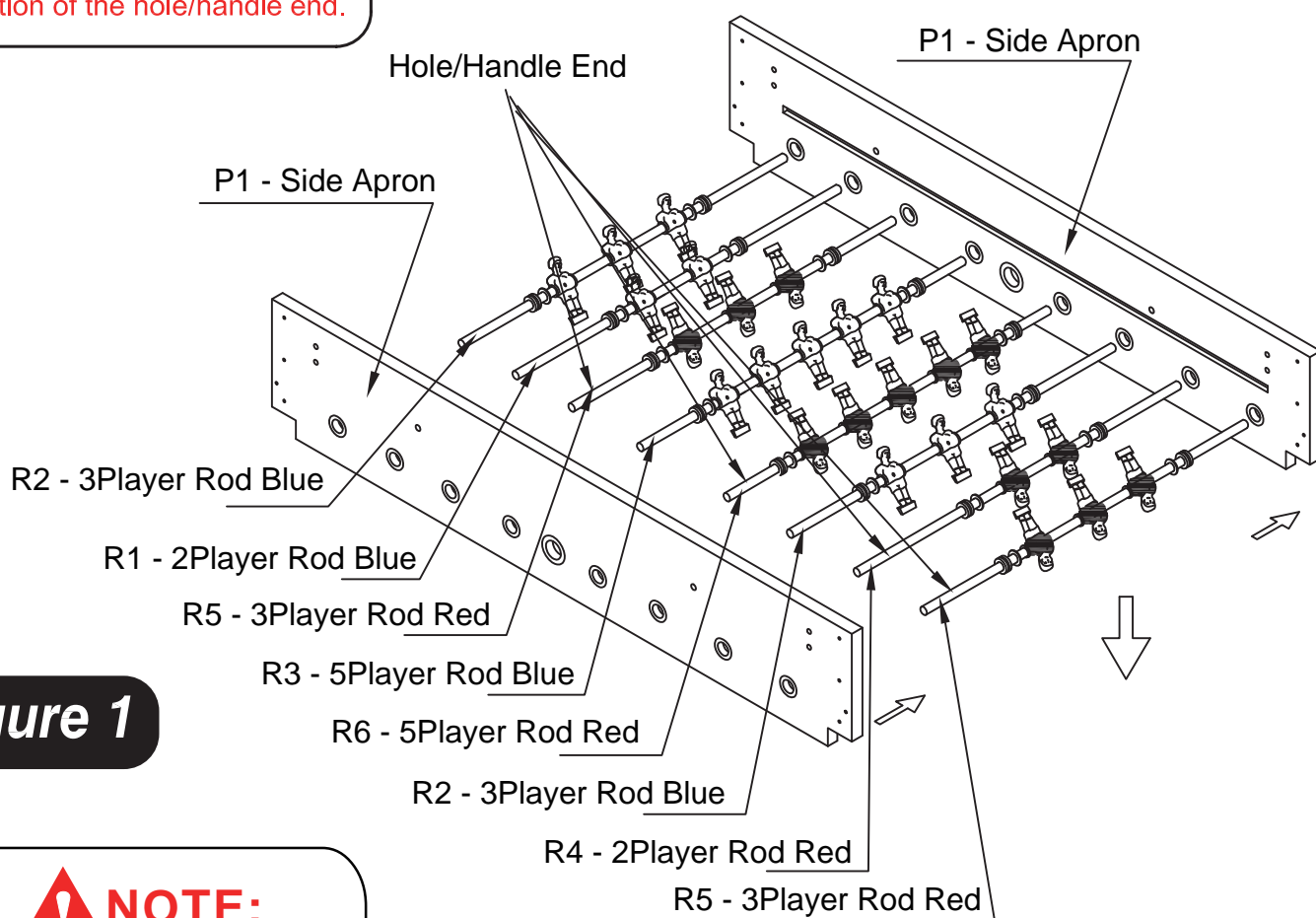

Figure 1



NOTE:

Dark players are red light players a blue.

5. Locate one End Apron P2 between the Side Aprons P1, screw it with four of Screws H6.
NOTE: Leave connections loose - Do not tighten screws securely at this time.
6. Slide the Playfield P3 with graphics facing down into the groves in the side aprons as shown in **FIGURE 2**. If the field does not slide smoothly, check to be sure you have not over tightened any screws or the playfield is not caught by the slot.

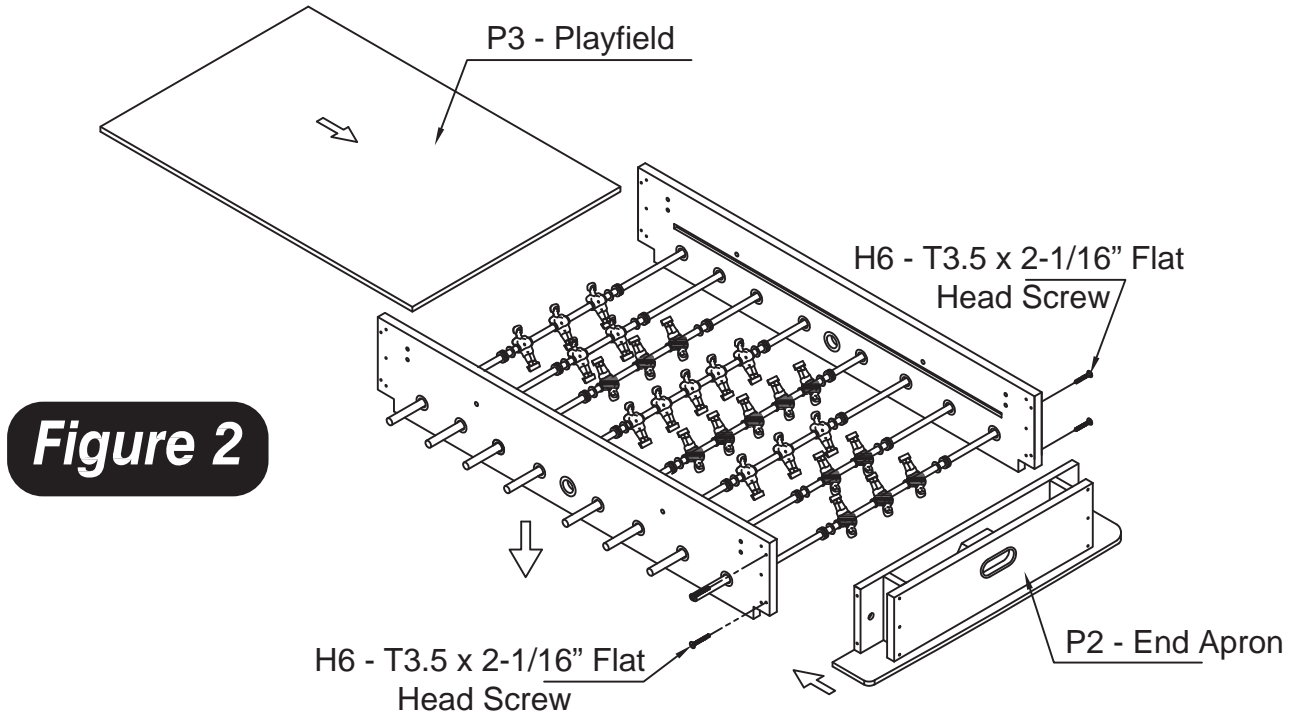

7. Repeat the step to attach the other End Apron P2 to the Side Aprons P1.
8. Place two Support Braces P4 on Playfield P3 as shown in **FIGURE 3**. Attach them using four of Washer Head Screw H5 as shown in **FIGURE 3**.

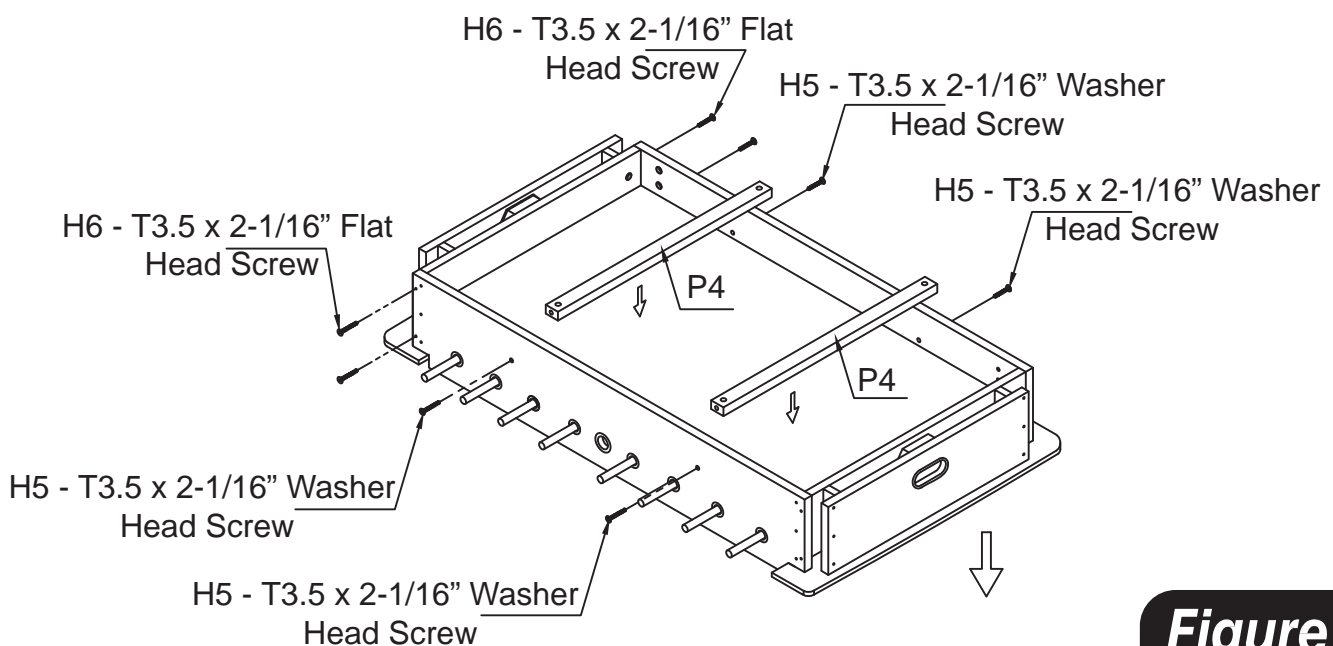

Figure 3

9. Attach apron corner **P11** to the cabinet using washer Head screw **H4** as shown in **FIGURE 4**.

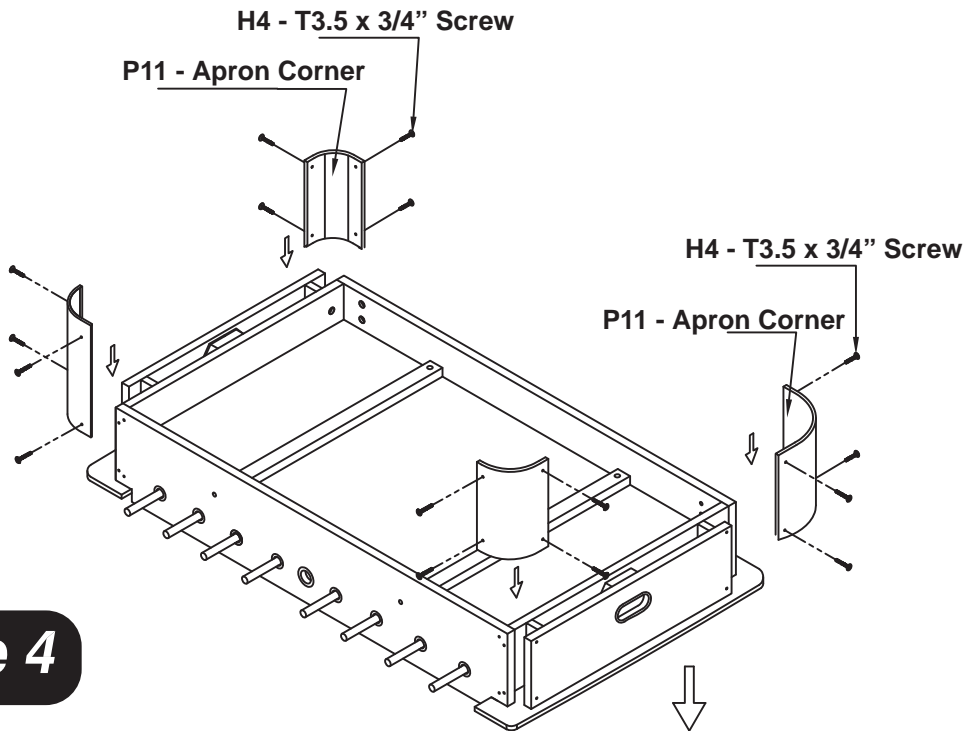

Figure 4

10. Attach the Left Leg **P5** and Right Leg **P6** to the cabinet using Leg Bolts **H1** and Washer **H2** as shown in **FIGURE 5**.

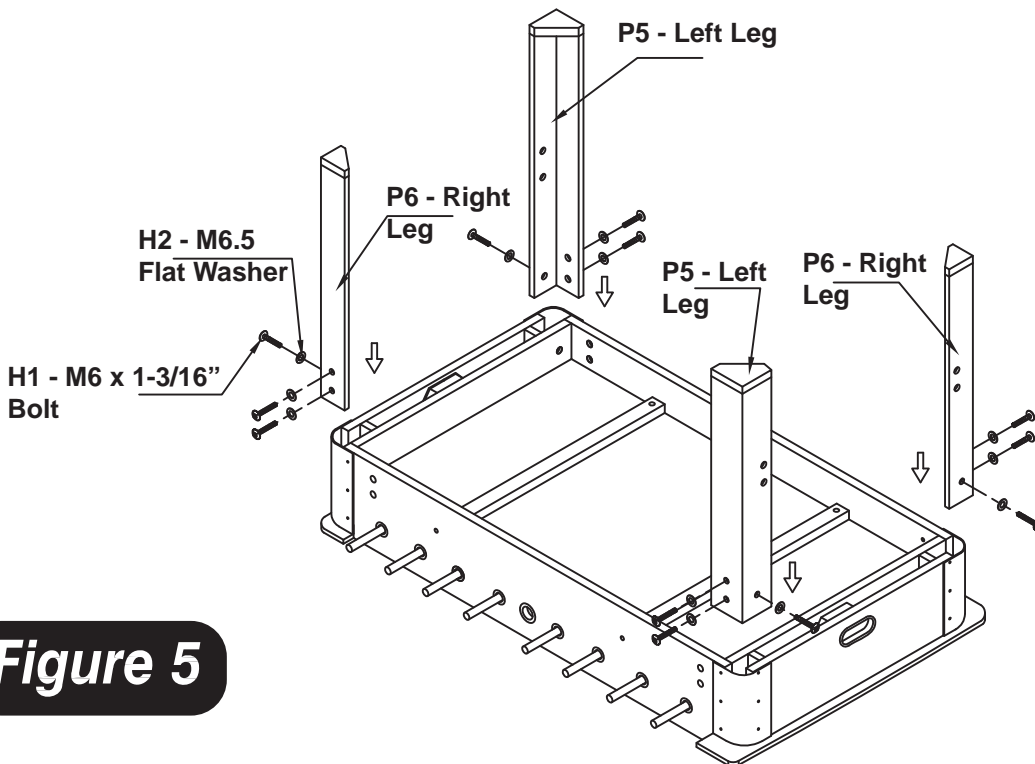

Figure 5

11. Attach End Leg Panel **P7** in side to Legs **P5** and **P6** using Bolt **H7** as shown in **FIGURE 6**.

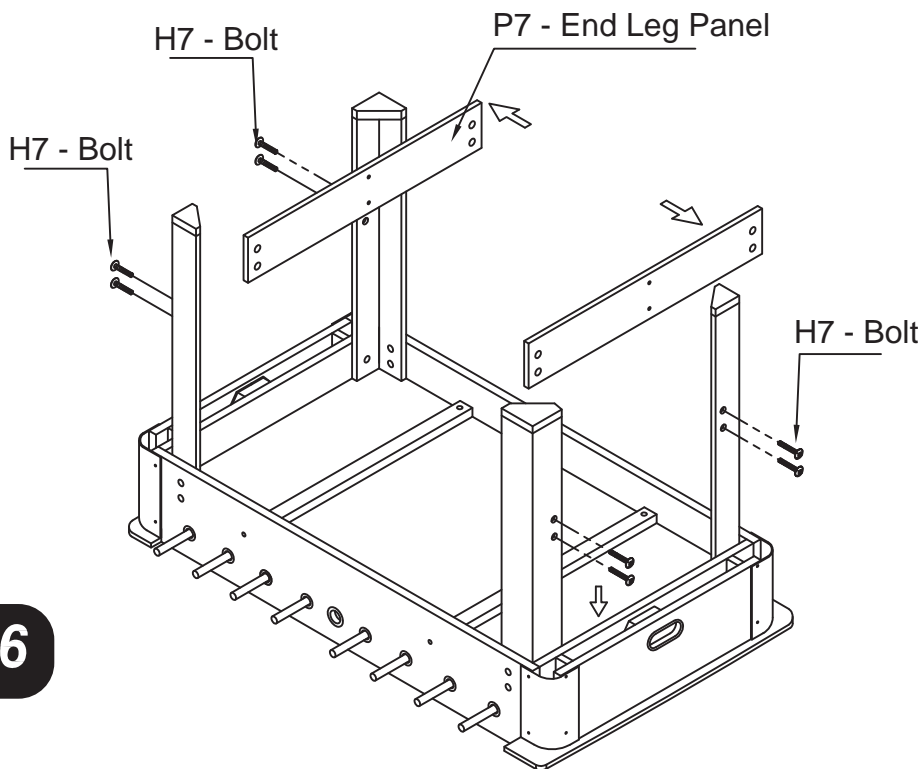

Figure 6

12. Attach Middle Leg Panel **P8** to End Leg Panel **P7** using Washer Head Screw **H8** as shown in **FIGURE 7**.

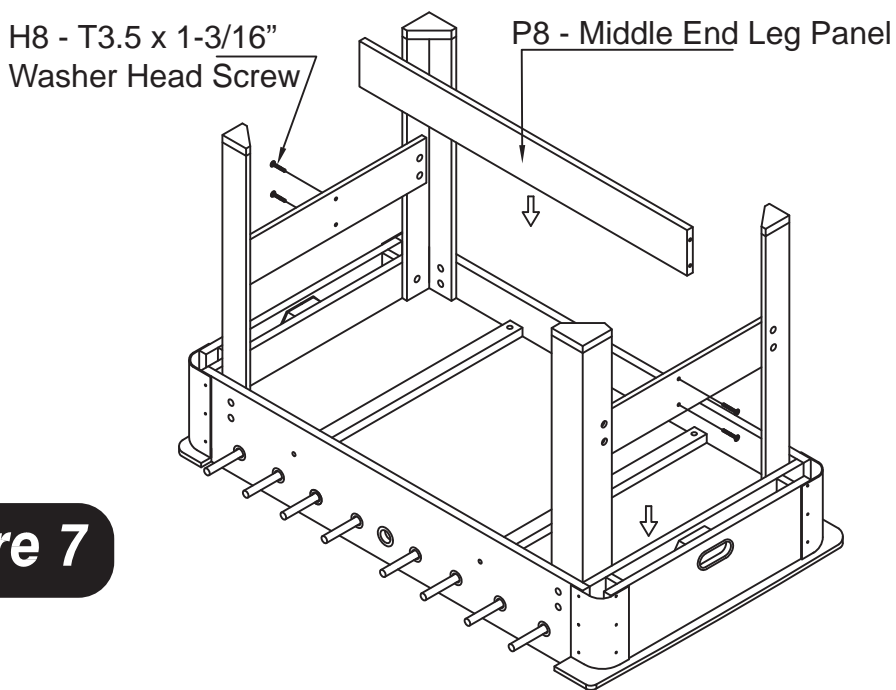

Figure 7

13. Slide the rod handles **P9** on the end of the rod with the hole closest to the end. Make sure the rod handles go on completely. A drop of liquid soap will help them slide on the rod. Slide the rod end cap **P10** on the other end of the rod.
14. Screw scorers P12 and P13 to the center of the end apron P2 top rail using screw H3 as shown in FIGURE 8.
Note: Screw the scorer to compare with goalie color.

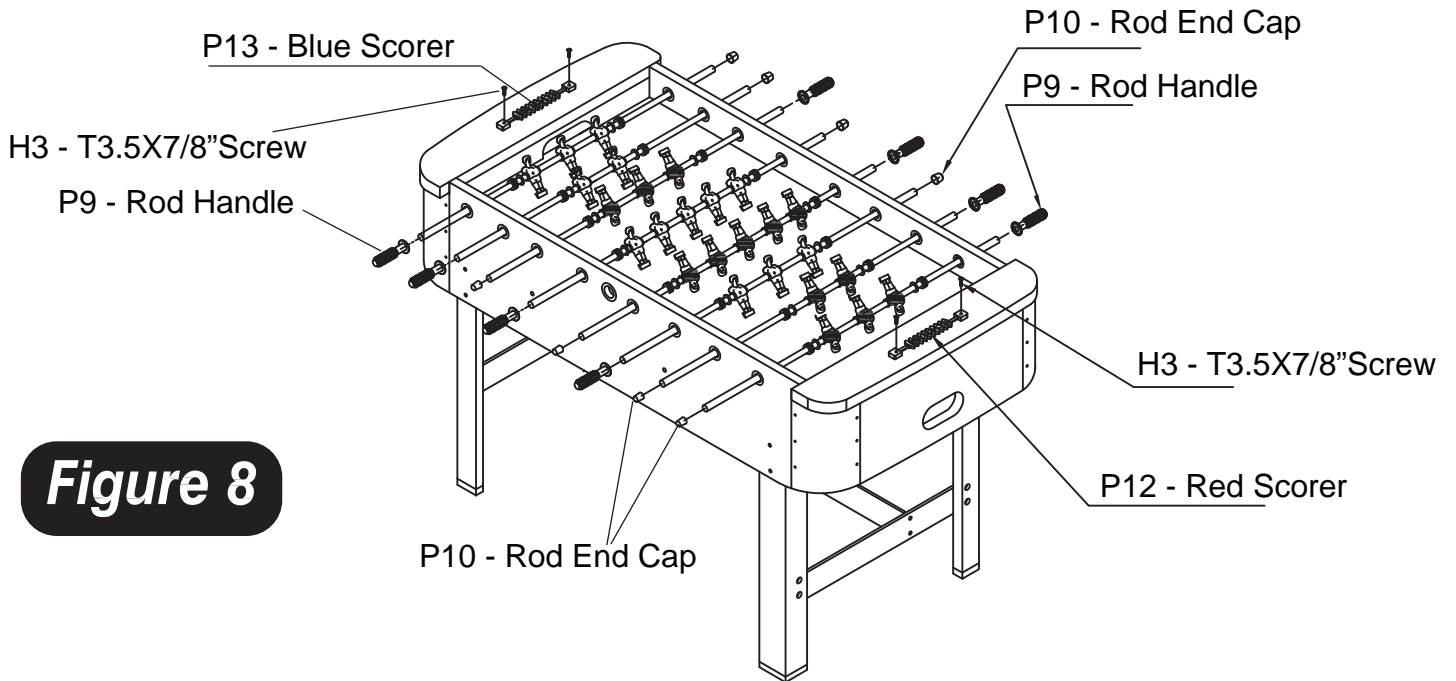

Figure 8

TABLE SOCCER

Table soccer is also called “foosball.” It can be played by two teams of four players each or by two individuals:

The Object of the Game

To be the first team (or player) to score a predetermined number of points or to score the most points in given amount of time.

Serving

The server rolls the ball through the serving hole to start the game, after a point is scored, or after a ball leaves the table. The server can spin the ball to influence the serve, but the ball must be struck by one of the serving team’s (or server’s) player figures. Once the ball is in play, it remains in play until it is hit off the table, a dead ball is declared, time out is called, or a point is scored.

Passing

If a ball is pinned on the 5-man rod, it cannot be passed to the 3-man rod of the same team without touching at least two player figures as it is being passed.

Scoring

When a ball enters the opposing team’s goal, a point is scored. If the ball enters the goal, but bounces back onto the playing surface or leaves the table, it still counts as a goal.

Spinning Rods

Spinning the rods is illegal.

Ball Off the Table

If the ball leaves the playing surface and strikes any object that is not part of the table, it is declared “off the table” and should be put back into play by a serve from the team (or player) that originally served that ball. If the ball rolls into the serving cup and then returns to the playing surface, it is still considered “in play.”

Dead Ball

If a ball has completely stopped its motion and cannot be reached by any player figure, it is declared a “dead ball.” If the ball is declared dead between the goal and the 2-man rod, it should be put back into play by placing it in nearest corner and releasing it. If the ball is declared dead anywhere else on the playing surface, it should be put back into play by a serve from the team that originally served the ball. If a ball is spinning in place, it is not considered a dead ball.